



# BUILDING and STRUCTURE SETBACK PERMIT

**BYLAW N° 2480**

FEB, 24, 1982

APPLICATION IS HEREBY MADE TO (CHECK ONE OF THE FOLLOWING TO INDICATE PROPOSED WORK)

<input type="checkbox"/> CONSTRUCT A NEW BUILDING ON VACANT LAND	<input type="checkbox"/> CONSTRUCT A NEW BUILDING ON OCCUPIED LAND
<input type="checkbox"/> ALTER AN EXISTING BUILDING	<input type="checkbox"/> OTHER _____ (SPECIFY)

**LOCATION OF PROPOSED BUILDING OR STRUCTURE**

LOT NO. \_\_\_\_\_ REG. PLAN \_\_\_\_\_ CONC. \_\_\_\_\_  
 SIDE OF ROAD: \_\_\_\_\_ ROAD NO. \_\_\_\_\_ ROAD NAME \_\_\_\_\_  
 LOCATION: \_\_\_\_\_ MUNICIPALITY \_\_\_\_\_

**EXISTING DRAINAGE**

<input type="checkbox"/> OPEN ROADSIDE DITCH	<input type="checkbox"/> OPEN MUNICIPAL DRAIN _____ NAME OF DRAIN
<input type="checkbox"/> CLOSED IN DITCH, TILE OR STORM SEWER	<input type="checkbox"/> CLOSED IN MUNICIPAL DRAIN _____ NAME OF DRAIN

**APPLICANT (OWNER)**

NAME \_\_\_\_\_ PHONE N° \_\_\_\_\_  
 ADDRESS \_\_\_\_\_ DATE \_\_\_\_\_  
 \_\_\_\_\_  
 (POSTAL CODE)

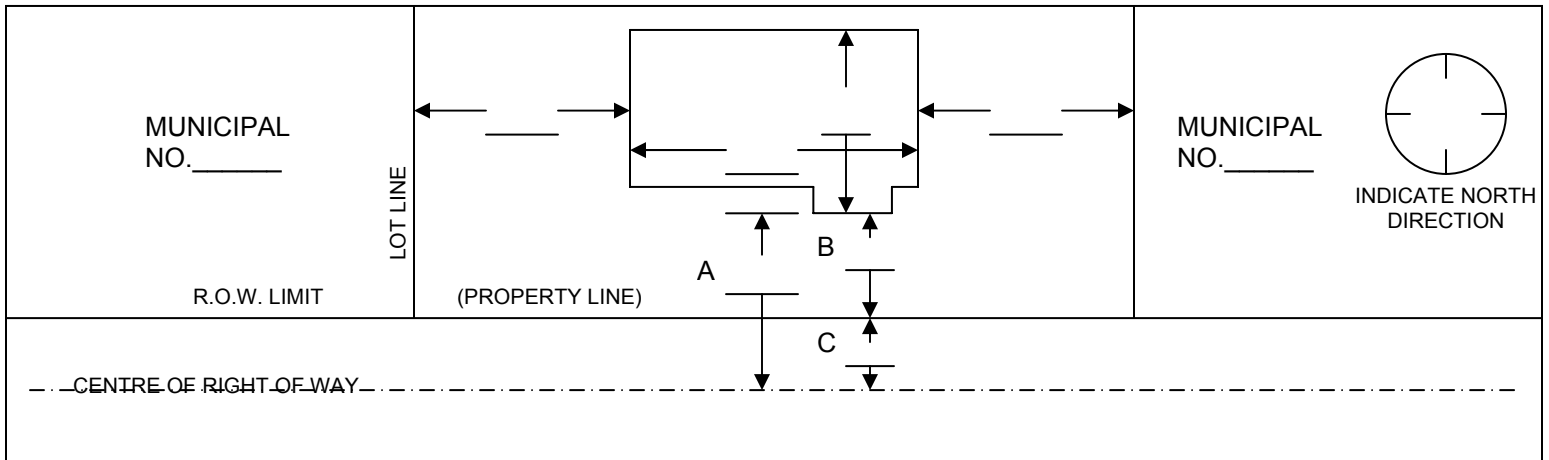

**IMPORTANT:**

- SHOW ALL DIMENSIONS, EXCEPT SETBACK DISTANCES "A", "B", & "C", WHICH WILL BE PROVIDED BY THE COUNTY.
- ATTACH DRAWINGS, SURVEY PLANS, ETC.
- INDICATE LOCATION OF PROPOSED OR EXISTING ENTRANCE(S)

**ENTRANCE INFORMATION**

EXISTING – NO CHANGE IN CLASSIFICATION OR DESIGN  
 EXISTING – ALTERATIONS PROPOSED: ENTRANCE PERMIT REQUIRED  
 NEW ENTRANCE PROPOSED: ENTRANCE PERMIT REQUIRED

VERIFICATION OF INFORMATION: OWNER: \_\_\_\_\_ SIGNATURE BUILDING INSPECTOR: \_\_\_\_\_ SIGNATURE

**FORM TO BE COMPLETED TO THIS LINE BY APPLICANT & BUILDING INSPECTOR**

PERMIT FEE		APPROVAL	
AMOUNT:	RECEIPT N°:	ISSUED BY:	
DATE:		DATE:	
RECEIVED BY:		REMARKS:	

**S-** \_\_\_\_\_  
 PERMIT N° \_\_\_\_\_ EXPIRY DATE \_\_\_\_\_

NOTE: APPLICANT TO CALL COUNTY ENGINEERING DEPT. WHEN WORK IS TO BEGIN (776-6441)

DISTRIBUTION:  Applicant  Engineer  Treasurer  Municipality